

**Whitco**<sup>®</sup>  
SECURING YOUR HOME™

# Hinged Security

## Door Hardware



# Hinged Security Door Hardware

## Tasman

### Application / Description

Single or Multi point hinged security or screen door lock

### Features and Specifications

#### DUALSELECT

DualSelect offers safety and security for all occupants by giving a choice of selecting privacy-lock or deadlock when exiting the home. Turning the key to the first selection engages the privacy-lock, which offers security from the outside whilst allowing occupants inside to safely exit using the internal privacy snib. The second selection engages the deadlock, which provides security, but requires the key to unlock the door from inside and outside

Internal padlock symbol denotes door is in deadlock mode

Contemporary styled furniture with pre-assembled handles and snib

Patented anti-jemmy extra wide serrated locking bolt

#### S1 SECURITY

#### D3 DURABILITY

High performance lock meets or exceeds relevant requirements of Australian Standard AS 4145.2-1993 to Level S1 and D3

Successfully tested on security screen doors in accordance with Australian Standard AS 5039-2003: Security Screen Doors and Security Window Grilles and AS 5041-2003: Methods of test

Optional 2 point kit for pool applications and 3 point kits for premium security available

Snib locking of all 3 points

Patentable features for centre and auxiliary locks

Available in polyester powdercoat and plated finishes

Fits industry standard cut outs  
Retrofits previous Whitco Tasman lock  
Zinc diecast lock mechanism and furniture  
Manufactured in Australia

Easy installation  
Suits either left or right hand opening hinged security and screen doors

Mortice lock with inside snib

Key overrides snib

Automatic latching

Accepts Whitco Euro profile lazy cam cylinder

Suit standard 20 mm door thickness

Stainless steel strikes

Available in Display and Trade packs

### Keying

Use with Whitco Euro profile lazy cam cylinder locks

2 x 5 pin cylinder

2 x 10 disc cylinder

### Non Standard Finishes

Other polyester powder coat finishes available on application

Aluminium

Steel



Security Screen



Flyscreen

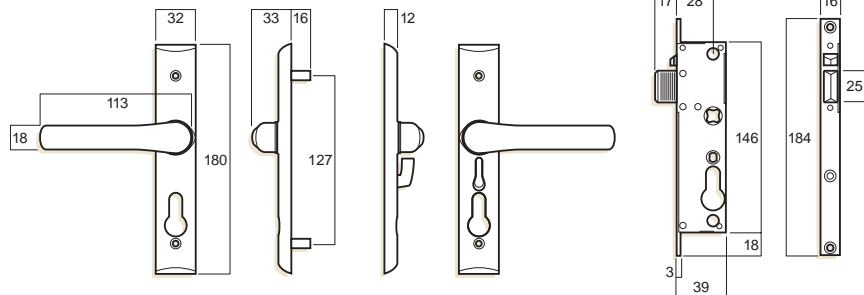

### Accessories

#### Strike – Centre lock

Standard (Stainless steel) W804000

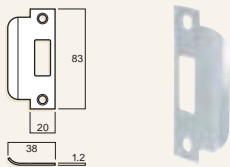

Anti-jemmy Kit (Stainless steel) W804400

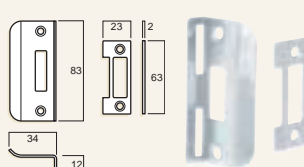

12 mm Step Over (Stainless steel) W804100

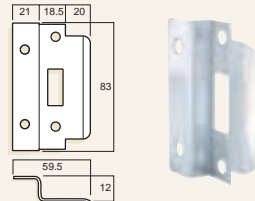

Strike Packer (Zinc diecast) W844100

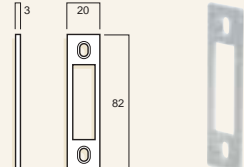

High Security (Stainless steel) W804300

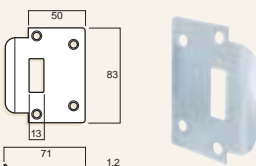

Extra Width (Stainless steel) W804500

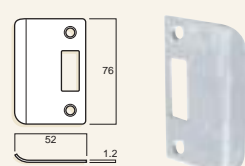

10 mm Step Over (Stainless steel) W804200

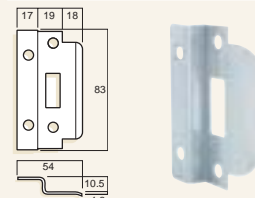

Lock cage W841100

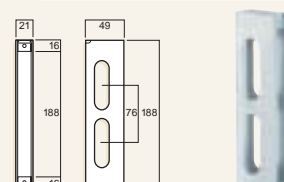

# Hinged Security Door Hardware

## Tasman Multi Point Lock Accessory Kits

### Application / Description

Used in conjunction with the Tasman Hinged Security and Screen Door Lock

### Features and Specifications

Universal auxiliary locks and rods

Snib operates all 3 locks

Easy installation

Snap-on-fix actuating bar suits above or below centreline applications and wider door sections

Patentable auxiliary locks

**S1 SECURITY**

**D3 DURABILITY**

High performance lock meets or exceeds relevant requirements of the Australian Standard AS 4145.2 - 1993 to Level S1 and D3

Successfully tested on security screen doors in accordance with Australian Standard AS 5039-2003: Security Screen Doors and Security Window Grilles and AS 5041-2003: Methods of test

Auxiliary bolts serrated for added anti-jimmy security

Zinc diecast

Galvanised steel connecting rods

Galvanised steel auxiliary lock cover plates

Available in Trade pack only

Stainless steel strikes

### Keying

Not Keyed

### Non Standard Finishes

Other polyester powder coat finishes available on application

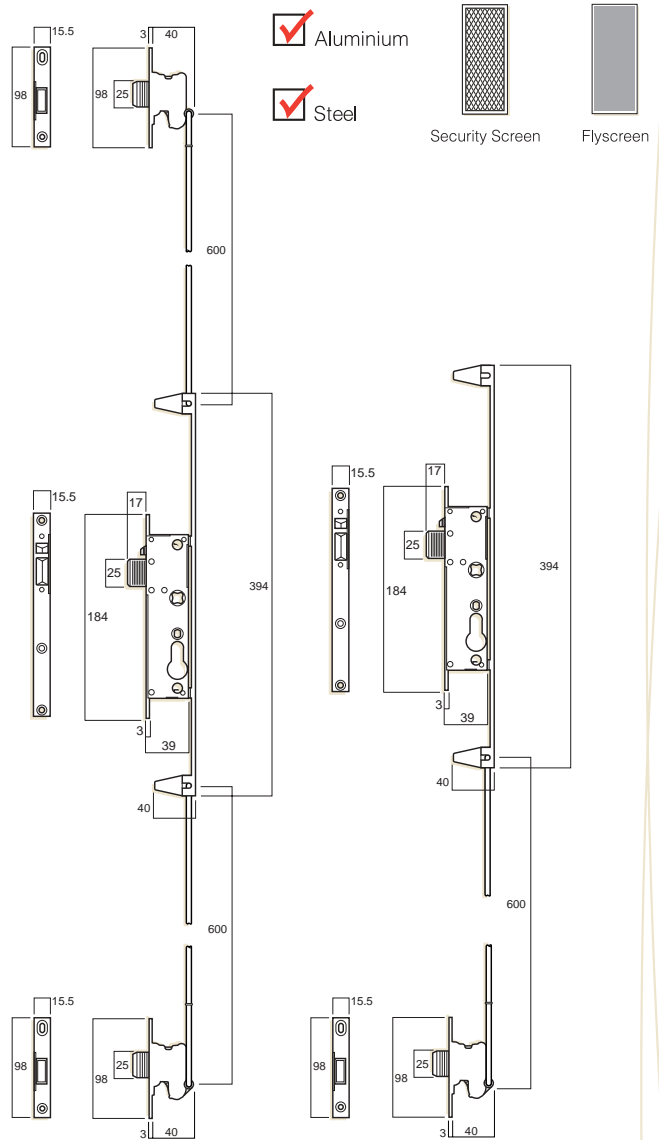

3 Point Lock Accessory Kit  
W803117

2 Point Lock Pool Kit  
W803217

## Accessories

3 Point Auxiliary - High Security (Stainless steel)

W800300

10 mm Step Over (Stainless steel)

W800500

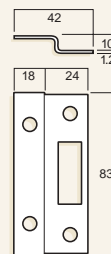
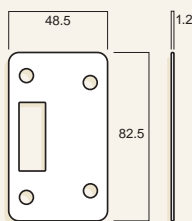

12 mm Step Over (Stainless steel)

W800400

3 Point Auxiliary Lock Support Plate (Black, Stainless steel)

W800617

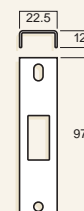
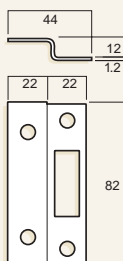

## Hinged Security Door Hardware

### Standard Finishes

Furniture available in the following polyester powder coat finishes.

 Silver 11	 Mahogany 12	 Brown 13	 White 16
 Black 17	 Gold Spangle 18	 Primrose 19	 Hawthorn Green 20
 Magnolia 24	 Ranch Brown 25	 Stone Beige 28	

### Ordering

•• Denotes finish. See price list for available pack / finish combinations.

#### Display Pack

Standard Strike, Anti-jemmy Strike Kit, Standard Furniture, Cylinder, Spindle, Fixing Screws and Screw Hole Plugs W8011••

#### Trade Pack

##### Centre Lockset

Standard Strike, Standard Furniture, No Cylinder, Spindle, Screws and Screw Hole Plugs W8012••

Extended Snib, Standard Strike, Standard Furniture, No Cylinder, Suits 37 mm Doors, Extended Spindle and Screws W8013••

Anti-jemmy Strike, Standard Furniture, No Cylinder, Screws, Spindle and Screw Hole Plugs W8015••

No Snib, Standard Strike, Standard Furniture, No Cylinder, Screws, Spindle and Screw Hole Plugs W8014••

Lock Box Only W8030••

##### Multi Point Lock Accessory Kit

Auxiliary Locks, Rods, Standard Strikes, Step Over Strikes

3 Point Lock Kit W803117

2 Point Lock Pool Kit, 1 Auxiliary Lock, Long Connecting Rod, Standard Striker and Screws W803217

# Hinged Security Door Hardware

## Triple Lock

### Application / Description

Single or multi point hinged security door lock

### Features and Specifications

Suits either left or right hand opening hinged security screen doors

Easy handling of bolt with adjusting screw

Accepts Whitco Euro profile lazy cam cylinder lock

Suits standard 20 mm thick door

Optional single point version

### Keying

Use with Whitco euro profile lazy cam cylinder locks

2 x 5 pin cylinder

2 x10 disc cylinder

### Non Standard Finishes

Other polyester powder coat finishes available on application

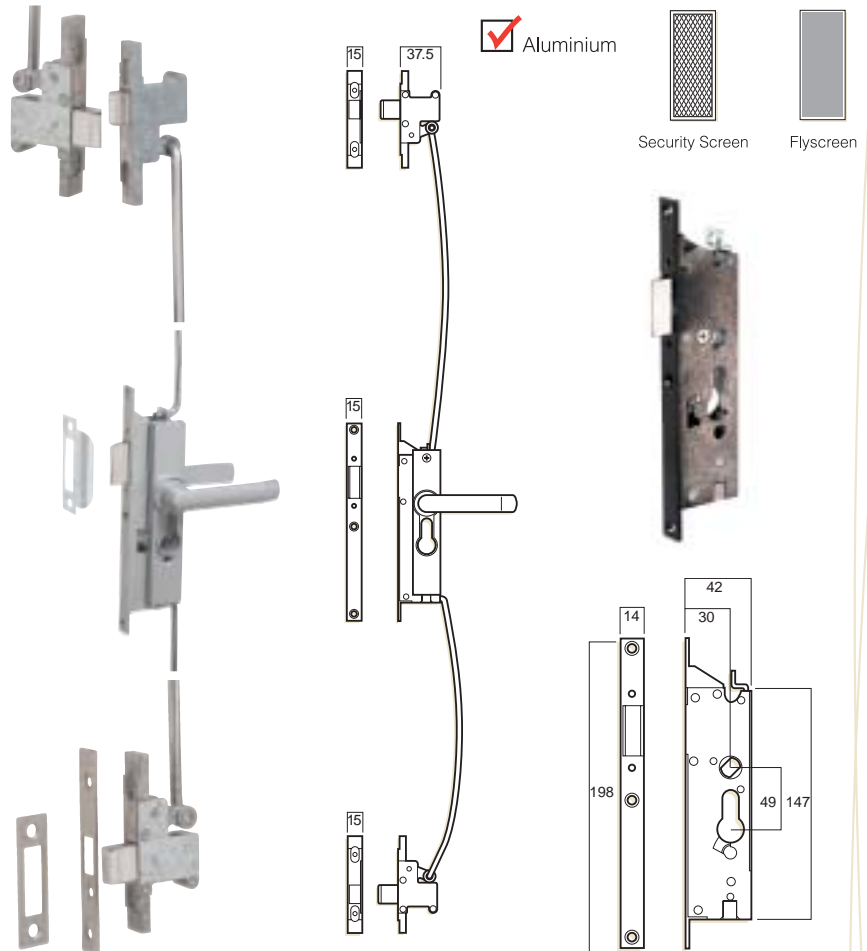

## Standard Finishes

Furniture available in the following polyester powder coat finishes.

 Silver 11

 Brown 13

 White 16

 Black 17

 Gold Spangle 18

 Primrose 19

## Ordering

Furniture, Centre Lock, Standard Strikes, Auxiliary Locks, Face Plates, Connecting Bars, No Cylinder, Screws

W8703●●

Centre Lock Only

W8713●●

## Accessories

Anti-jemmy Kit (Stainless steel)

W844204

Extra Width Strike

W844300

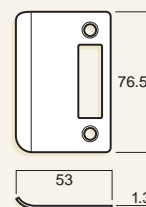
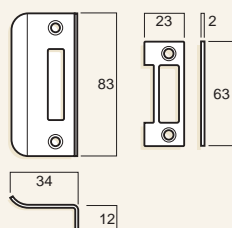

## Hinged Security Door Hardware

### Safety Lock

#### Application / Description

Keyed hinged screen door lock

#### Features and Specifications

Suits either left or right hand opening hinged screen doors – reversible latch bolt to suit inward or outward opening doors

Surface mounted lock

Key lock from inside or outside

Zinc diecast construction

Suits standard 20 mm door thickness

Available in Display and Trade packs

Made to Whitco specifications

#### Keying

10 disc integral barrel

Two Whitco chrome plated brass keys

#### Non Standard Finishes

Other polyester powder coat finishes available on application

#### Accessories

No accessories are available for this product

Aluminium

Timber



Flyscreen

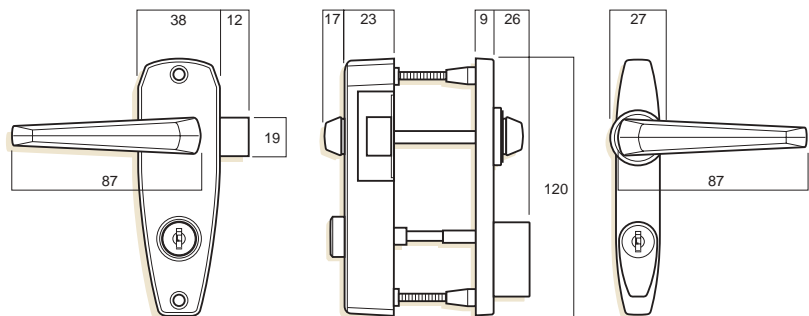

### Standard Finishes

Available in the following polyester powder coat finishes.

Brown 13

White 16

Black 17

### Ordering

•• Denotes finish. See price list for available pack / finish combinations.

#### Display Pack

Lock and Strike with Screws

W8505••

#### Trade Pack

Single Pack

W8501••

2 Keyed Alike

W851217

10 Keyed Alike

W851017

# Hinged Security Door Hardware

## Caravan Screen Door Lock

### Application / Description

Keyed hinged screen door lock

### Features and Specifications

Suits either left or right hand opening hinged screen doors – reversible latch bolt to suit inward or outward opening doors

Surface mounted lock

Inside snib, key lock outside

Zinc diecast construction

Maximum door thickness 42 mm

Available in Trade pack

Made to Whitco specifications

### Keying

10 disc integral barrel

Two Whitco chrome plated brass keys

### Non Standard Finishes

Other polyester powder coat finishes available on application

### Accessories

No accessories are available for this product

Aluminium

Timber

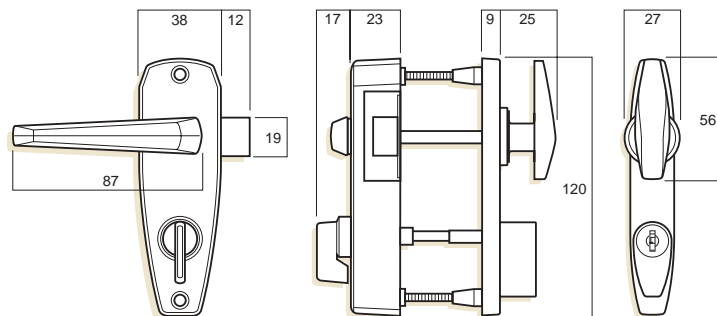
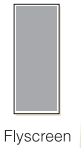

### Standard Finishes

Available in the following polyester powder coat finishes.

Brown 13

White 16

Black 17

### Ordering

#### Trade Pack

Single Pack

W850217

## Hinged Security Door Hardware

### Cylinder – Euro Profile Lazy Cam

#### Application / Description

Cylinder to suit Whitco Leichhardt, Tasman and Tasman Escape security screen door locks

#### Features and Specifications

- Available in Bright Chrome.
- Double cylinder, C4 key profile
- Brass and zinc diecast construction
- Display and Trade packs available
- Made to Whitco specifications

#### Keying

Two versions available:

- 2 x 5 pin, C4 key profile cylinder lock, can be keyed alike to other Whitco 5 pin C4 cylinder locks
- 2 x 10 disc, profile cylinder locks
- Two Whitco chrome plated brass keys included

#### Non Standard Finishes

Other finishes are not available

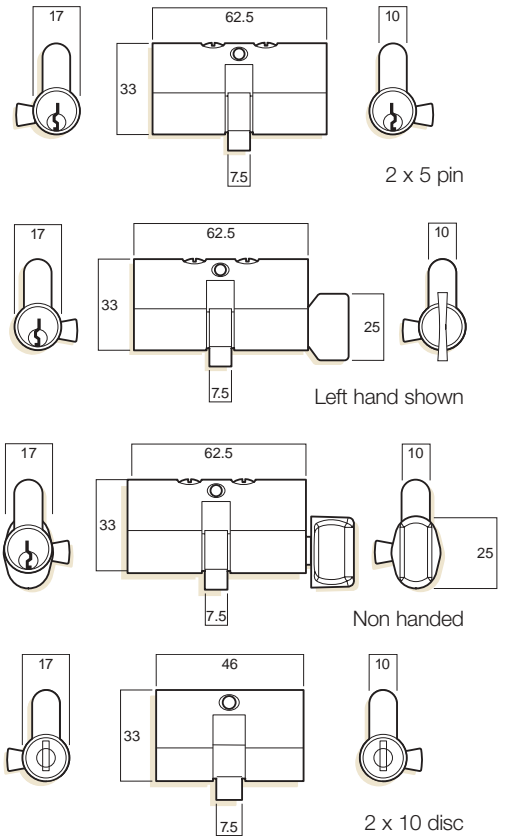

#### Standard Finishes

Bright Chrome 00

#### Ordering

Bright Chrome unless otherwise stated

##### Display Pack

###### Double Cylinder

2 x 5 Pin with screw	W840700
2 x 10 Disc with screw	W840800

##### Trade Pack

###### 2 x 5 Pin / Double Cylinder

Random Keyed	W841200
2 Keyed Alike	W842200
3 Keyed Alike	W842300
4 Keyed Alike	W842400
10 Keyed Alike	W842500
10 Keyed Alike – Gold Plated	W842502
20 Keyed Alike	W842600
50 Keyed Alike	W842800

###### Turnknob & 5 Pin

Random Keyed Turnknob & 5 Pin / Right Hand	W845500
Random Keyed Turnknob & 5 Pin / Left Hand	W845600
2 Keyed Alike / Turnknob & 5 Pin / Right Hand	W845700
2 Keyed Alike / Turnknob & 5 Pin / Left Hand	W845800
Random Keyed / Non-handed Turnknob & 5 Pin	W841500
2 Keyed Alike / Non-handed Turnknob & 5 Pin	W841600

###### 2 x 10 Disc / Double Cylinder

Single Random Keyed	W841400
2 Keyed Alike	W843200
3 Keyed Alike	W843300
4 Keyed Alike	W843400
10 Keyed Alike	W843500
20 Keyed Alike	W843600

#### Use in

- Whitco Leichhardt Sliding Security Screen Door Lock
- Whitco Tasman Hinged Security Screen Door Lock
- Whitco Triple Lock Hinged Security Screen Door Lock
- Whitco Tasman Escape Hinged Security Screen Door Lock



# Hinged Security Door Hardware

## Screen Door Latch

### Application / Description

Hinged screen door latch

### Features and Specifications

Suits either left or right hand opening hinged screen doors

Surface mounted latch

Inside snib

Maximum door thickness 25 mm

Available in Display and Trade packs

Made to Whitco specifications

Zinc die cast construction with steel strike

### Keying

Not keyed

### Non Standard Finishes

Other finishes are not available

### Accessories

No accessories are available for this product

Aluminium

Timber

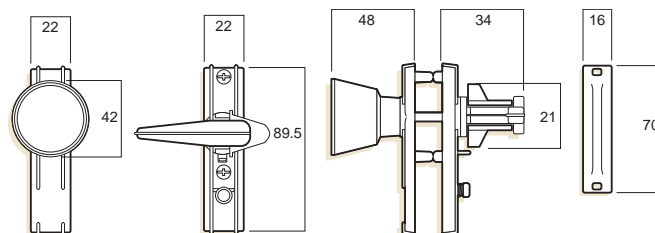

## Standard Finishes

Available in the following polyester powder coat finishes.

Silver 11

Brown 13

White 16

Black 17

## Ordering

•• Denotes finish. See price list for available pack / finish combinations.

### Display Pack

W8203••

### Trade Pack

W8201••

# Hinged Security Door Hardware

## Screen Door Closer

### Application / Description

Hinged screen and security screen doors

### Features and Specifications

Smooth pneumatic operation

Suits either left or right hand closing hinged doors

Adjustable closing speed with hold open bracket

Surface mounted

Tough aluminium and UV resistant ABS polymer construction

Standard and Heavy duty versions

Display and Trade packs available

Australian made

Aluminium

Timber



Security Screen



Flyscreen



### Keying

Not keyed

### Non Standard Finishes

Other polyester powder coat finishes available on application

### Accessories

No accessories are available

### Performance

Standard version suitable for screen door or security doors up to 18 Kg

Heavy Duty version suitable for screen door or security doors up to 25 Kg

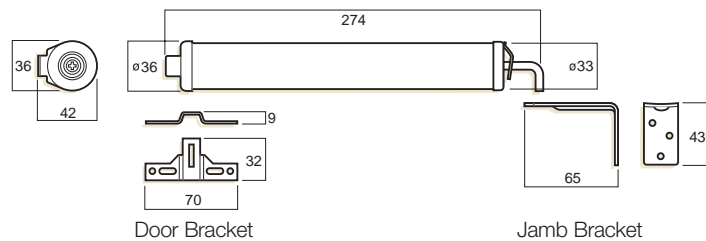

## Standard Finishes

Available in the following polyester powder coat finishes.

<input type="checkbox"/> Silver 11	<input type="checkbox"/> Pottery 14	<input type="checkbox"/> White 16	<input type="checkbox"/> Black 17
<input type="checkbox"/> Gold Spangle 18	<input type="checkbox"/> Primrose 19	<input type="checkbox"/> Hawthorn Green 20	<input type="checkbox"/> Doeskin 23
<input type="checkbox"/> Magnolia 24	<input type="checkbox"/> Ranch Brown 25	<input type="checkbox"/> Stone Beige 28	

## Ordering

•• Denotes finish. See price list for available pack / finish combinations.

### Display Pack

Standard W8107••

### Trade Pack

Standard W8105••

Heavy Duty W8106••



## Sales Offices & Authorised Agents

### Victoria – Head Office

50 Edward Street  
Oakleigh VIC 3166  
Telephone (03) 8574 3888  
Facsimile (03) 8574 3788

### Queensland South

450 Sherwood Road  
Sherwood QLD 4075  
Telephone (07) 3373 5200  
Facsimile (07) 3373 5256

### Queensland North

Ralph Buck Agencies  
15 Mackley Street  
Garbutt QLD 4814  
Telephone (07) 4779 0177  
Facsimile (07) 4775 1480

### New South Wales – Commercial

Unit 1/16 Atkinson Road  
Taren Point NSW 2229  
Telephone (02) 8543 3700  
Facsimile (02) 9531 7944

### New South Wales – Residential

Unit 5/30 Foundry Road  
Seven Hills NSW 2147  
Telephone (02) 9620 9111  
Facsimile (02) 9620 9055

### South Australia

182 Magill Road  
Norwood SA 5067  
Telephone (08) 8364 1930  
Facsimile (08) 8364 1931

### Western Australia

45 Gladstone Street  
East Perth WA 6004  
Telephone (08) 9227 9588  
Facsimile (08) 9227 8913

### Tasmania

23 Antill Street  
South Hobart TAS 7000  
Telephone (03) 6223 5404  
Facsimile (03) 6224 0435

## Manufacturing Plants

### Victoria

50 Edward Street  
Oakleigh VIC 3166  
Telephone (03) 8574 3888  
Facsimile (03) 8574 3788

### Queensland

450 Sherwood Road  
Sherwood QLD 4075  
Telephone (07) 3373 5200  
Facsimile (07) 3373 5256

### Auckland

9B Mahunga Drive  
Mangere Bridge  
Auckland New Zealand  
Telephone (09) 634 5590  
Facsimile (09) 634 5589

### Christchurch

Unit 5, 8 Venture Place  
Christchurch New Zealand  
Telephone (03) 379 4810  
Facsimile (03) 379 4819

### Wellington

47 Kenepuru Drive  
Porirua  
Wellington New Zealand  
Telephone (04) 237 0808  
Facsimile (04) 237 0060

## Manufacturing Plants

### New Zealand

5 Armstrong Road  
North Harbour Industrial Estate  
Albany, Auckland NZ  
Telephone +64 (0)9 6224 804  
Facsimile +64 (0)9 6224 802

## Export Department

50 Edward Street  
Oakleigh VIC 3166  
Telephone +61 (0)3 8574 3888  
Facsimile +61 (0)3 8574 3789

## Asian Offices

### Assa Abloy – Malaysia

### Assa Abloy – Singapore

### Assa Abloy – Thailand

### Assa Abloy – Hong Kong

### Assa Abloy – Shanghai

### Assa Abloy – Beijing

Contact the Export Department,  
Australia for details.

## Worldwide Distributors

Contact the Export Department,  
Australia for details.



## Whitco Warranty

Whitco Pty Ltd ("Whitco") warrants its products to be free from defects in material and workmanship for a period of seven years from the date of purchase by the retail customer.

With exception, Whitco warrants all door screen & window screen products for a period of twelve months, excluding key locks and hinges therein which have a warranty of seven years from the date of purchase by the retail customer.

This warranty is limited at Whitco's option to the replacement of any product proven to be faulty in manufacture or materials, with the same or equivalent product free of charge. Labour charges, transportation and other costs associated with the replacement or re-installation of the parts or products are excluded from this warranty and will not be paid by Whitco.

Whitco assumes no liability under the warranty for the following:

- Misuse, abuse, accidental or intentional damage,
- Improper maintenance and installation,
- Unauthorised repair or modifications,
- Use contrary to instructions furnished by Whitco,

- Use of replacement parts other than authorised parts,
- Corrosion related damages when used in a corrosive environment,
- Tarnish or excessive wear on soft finishes such as Bronze, Brass and other Antique finishes is not covered by this warranty as deterioration is possible under some climatic conditions, frequency of use or other factors,
- Whilst Gold, Chrome and powder coated finishes are warranted against tarnish, they shall not be covered for deterioration caused by damage to the protective layer,
- Deterioration in colour and performance of polymer materials,
- Malfunction or failure of the product due to the use of non-genuine Whitco parts and cylinders.

To the extent permitted by law, Whitco shall not be liable to the purchaser, common user or any other person for any incidental or consequential damages arising howsoever and including but not limited to damages from any defect, malfunction or failure of any product or component.

To the extent permitted by law, this warranty is the exclusive warranty granted by Whitco and is in lieu of all other express or implied warranties. There are no implied warranties as to merchantability, quality or fitness for a particular purpose. In all other respects the Standard Terms and Conditions of Whitco apply.

